

# 3200ET Remote Meter

---

*Service Manual*

---

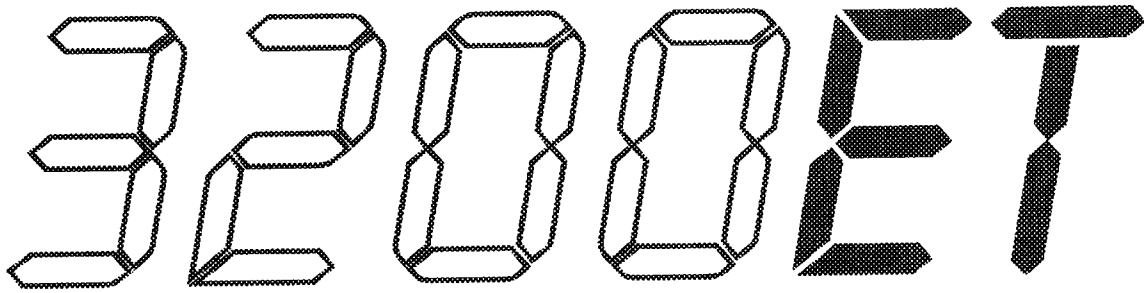

**IMPORTANT:** Fill in pertinent information on page 2 for future reference.

# 3200ET Remote Meter

---

## *Installation and Start-Up Procedures*

---

Record Remote Meter Programming Here:

Water Hardness \_\_\_\_\_

System Capacity \_\_\_\_\_

Regeneration Time \_\_\_\_\_

Regeneration Signal Time \_\_\_\_\_

Notes:

---

---

---

---

---

---

---

---

---

---

1. Follow the installation procedures contained within the remote meter service manual.
2. The remote meter/timer should be installed with the inlet and outlet and connections (if any) made in accordance with the manufacturer's recommendations and to meet all applicable plumbing codes.
3. Follow the installation and start-up procedures contained within each valve(s) service manual.
4. Referencing the wiring diagram furnished with each valve in the system, make the proper electrical connections to the remote timer. All electrical connections must be made in accordance with the manufacturer's recommendations and to meet all applicable electrical codes.
5. During cold weather it is recommended that the installer warm the remote timer up to room temperature before energizing.
6. Plug the remote timer into an approved power source. The valve(s) connected to the remote timer may then cycle themselves back to Service.

# 3200ET Remote Meter

## Installation and Start-Up Procedures (Cont'd.)

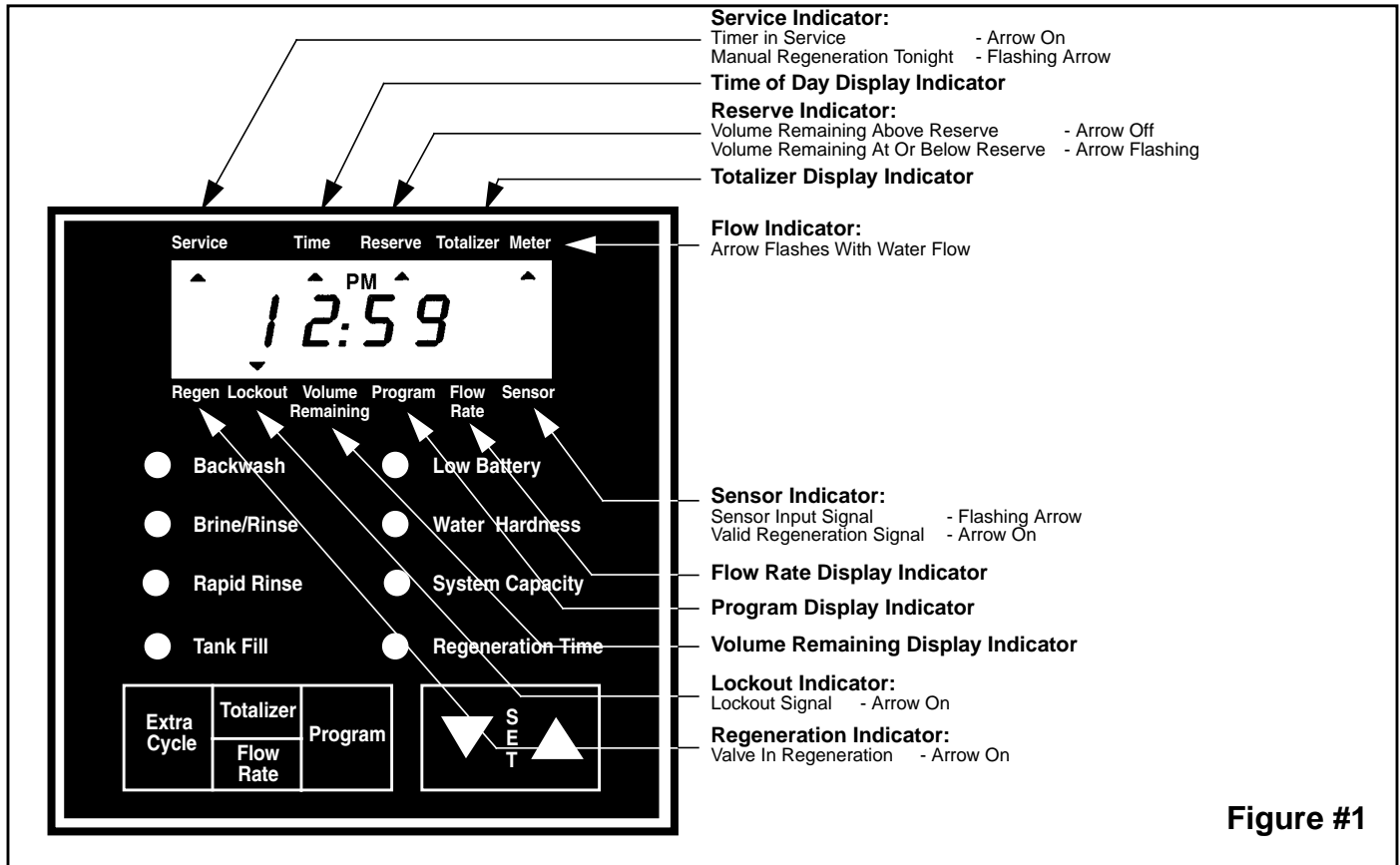
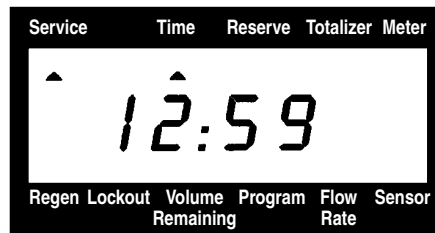

Figure #1

7. In normal operation the Time Of Day, and if flow meter equipped, Volume Remaining Displays alternate being viewed. Set the Time Of Day Display by depressing the Up or Down Set Button to the correct time. (See Fig. 1)

**For Example:**  
12:59 A.M.  
(Valve in Service)



8. **Remote Meters Only:** The Volume Remaining Display is the volume of water (in gallons) remaining prior to regeneration, including any reserve capacity. Without any water usage the Meter Arrow should be either off or on but not changing. Open a soft water tap. The Meter Arrow should begin flashing at a rate that varies with flow rate. Close the tap after 3 - 5 gallons of water flow.

**For Example:**  
125 Gallons Of Water Remaining  
(Valve in Service)  
(No Water Flow)  
(Volume is below reserve capacity, Reserve Arrow Flashing)

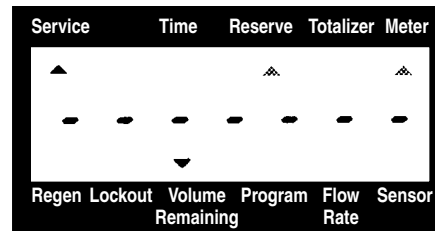
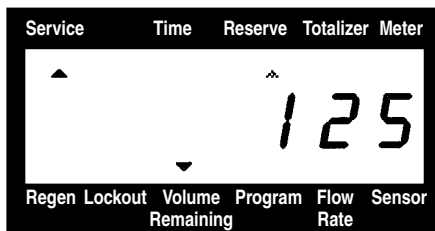

**For Example:**  
0 Gallons Of Water Remaining  
(Valve in Service)  
(Water Flowing, Meter Arrow Flashing)  
(Volume is below reserve capacity, Reserve Arrow Flashing)

# 3200ET Remote Meter

## Installation and Start-Up Procedures (Cont'd.)

9. Manually initiate a regeneration cycle of all valves in the system through the remote timer. Allow water to run to drain on each valve for 3 to 4 minutes. Manually step each valve through a complete regeneration cycle checking valve operation in each step.

A. Initiating Regeneration (Depending on the timer regeneration type you have one or two (2) Options):

1. **Press and Release the Extra Cycle Button.** With Immediate Regeneration Timers the control will go into regeneration immediately. With Delayed Regeneration Timers the Service Arrow will begin to flash immediately and a regeneration will occur at the preset regeneration time (i.e. 2:00 a.m.)
2. **Press and Hold for 5 seconds the Extra Cycle Button.** The control will go into regeneration immediately. Delayed Regeneration Timers Only)

B. Control Operation While Sending A Regeneration Signal:

1. When sending a regeneration signal the control will display the remaining signal time.

**For Example:**

(Timer is sending a 6.0 minute regen. signal)  
(Regeneration arrow on)

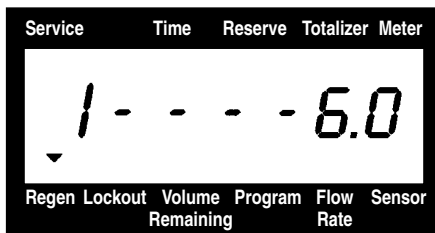

2. A red LED will also turn on to indicate that a regeneration signal is being sent.

**For Example:**

(Timer has sent 3.5 min. of a 6.0 min. signal))  
(2.5 minutes of signal time remain)  
(Regeneration arrow on)

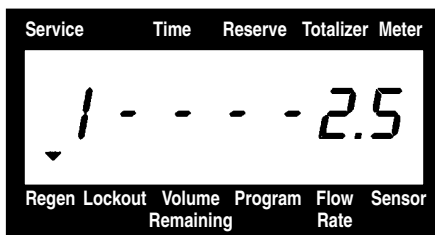

3. Pushing the Extra Cycle Button during a regeneration signal will immediately advance the timer back to Service.
  4. Pushing the Up or Down Set Button during a regeneration signal will adjust the signal time remaining. Programmed signal time **will not** be changed.
  5. Once the Regeneration Signal has been completed the timer will return to service and resume normal operation.
10. A **9V Alkaline battery** is recommended to be installed at all times for proper timer operation. The control will indicate when the battery needs to be replaced by turning on the Low Battery LED.

# 3200ET Remote Meter

## Control Operation

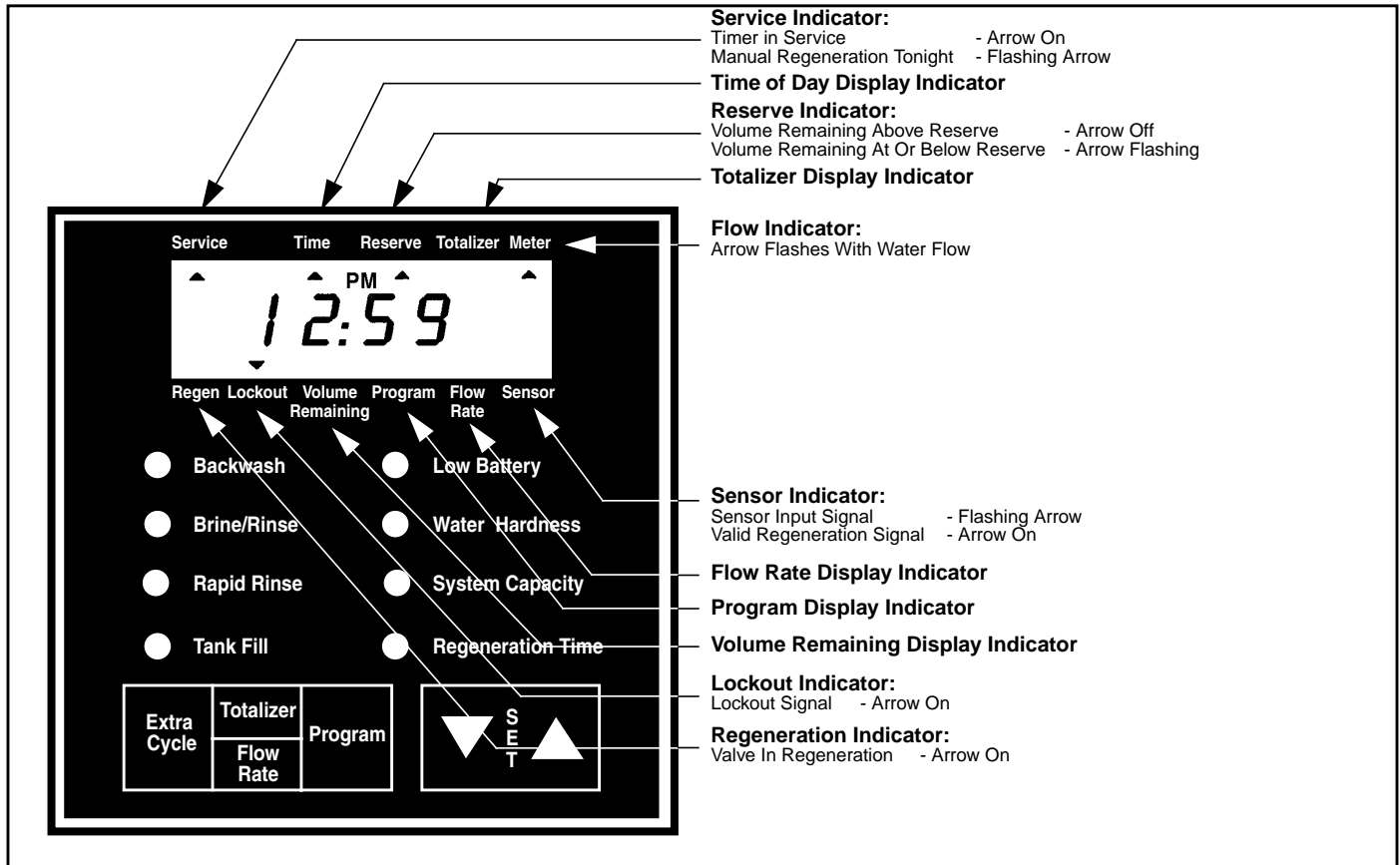

### Normal Operation

#### Remote Meter Delayed Regeneration Systems -

In Normal Operation the Time Of Day Display will alternate being viewed with the Volume Remaining Display. Water flow through the unit is indicated by the Meter Arrow that will flash in a direct relationship to flow rate. As treated water is used, the Volume Remaining Display will count down from a maximum value to the calculated reserve capacity. Once this occurs, the Reserve Arrow will begin to flash as an indication that reserve capacity is being used. At the preset Regeneration Time, a regeneration cycle will then be initiated immediately.

#### For Example:

**125 Gallons of Water Remaining**  
 (Timer in Service)  
 (No water flow)  
 (Volume is below reserve capacity)

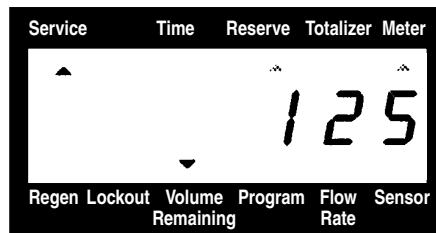

#### For Example:

**0 Gallons of Water Remaining**  
 (Timer in Service)  
 (Water flowing, Meter Arrow Flashing)  
 (Volume is below reserve capacity)

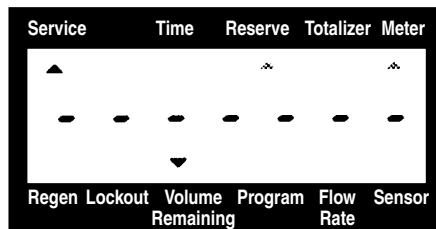

# 3200ET Remote Meter

## Control Operation (Cont'd.)

### Timeclock Regeneration Systems -

In Normal Operation the Time Of Day Display will be viewed at all times. The control will operate normally until the days since the last regeneration reaches the preset number of days. Once this occurs, a regeneration cycle will then be initiated immediately at the preset Regeneration Time.

### Remote Meter Immediate Regeneration Systems -

In Normal Operation the Time Of Day Display will alternate being viewed with the Volume Remaining Display. Water flow through the unit is indicated by the Meter Arrow that will flash in a direct relationship to flow rate. As treated water is used, the Volume Remaining Display will count down from a maximum value to zero. Once this occurs a regeneration cycle will then be initiated immediately.

**For Example:**

**525 Gallons of Water Remaining**

(Timer in Service)

(Water Flowing, Meter Arrow Flashing)

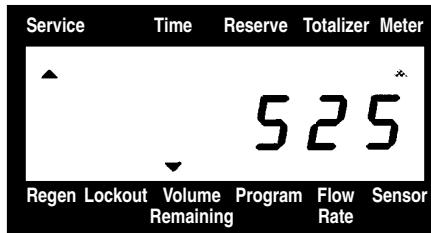

### Sensor Immediate Regeneration Systems -

In Normal Operation the Time Of Day Display will be viewed at all times. The control will operate normally until a valid sensor input signal is received. Once this occurs, a regeneration cycle will then be initiated immediately. The Sensor Input Arrow will flash until the signal is determined to be valid.

### Sensor Delayed Regeneration Systems -

In Normal Operation the Time Of Day Display will be viewed at all times. The control will operate normally until a valid sensor input signal is received. Once this occurs, a regeneration cycle will then be initiated immediately at the preset Regeneration Time. The Sensor Input Arrow will flash until the signal is determined to be valid. Then the Reserve Arrow will begin to flash as an indication that reserve capacity is being used.

**For Example:**

**12:58 P.M. With Invalid Sensor Signal**

(Timer in Service)

(Sensor Arrow Flashing)



**For Example:**

**12:59 P.M. With Valid Sensor Signal**

(Timer in Service)

(Sensor Arrow On)

(Reserve Arrow Flashing) (Delayed Regen)

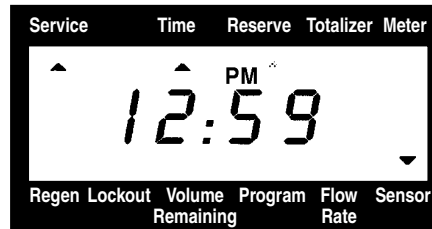

### Immediate Regeneration Systems With Days Between Regeneration Override Set -

When the control reaches its set Days Since Regeneration Override value a regeneration cycle will be initiated immediately. This event occurs regardless of the Volume Remaining display having reached zero.

### Delayed Regeneration Systems With Days Between Regeneration Override Set -

When the control reaches its set Days Since Regeneration Override value a regeneration cycle will be initiated at the preset Regeneration Time. This event occurs regardless of the Volume Remaining display having reached the calculated reserve capacity.

# 3200ET Remote Meter

## Control Operation (Cont'd.)

### Control Operation During A Power Failure

During a power failure all control displays will be turned off and regeneration cycles delayed. The control will otherwise continue to operate normally until line power is restored or battery backup power is lost.

1. If battery backup power is never lost during a power outage, the control will continue to operate normally, without the loss of data, until line power is restored.
2. If battery backup power is lost during a power outage, the control will store the current Time Of Day, Volume Remaining, Regeneration Signal Status, and various diagnostic displays. These stored displays will then be used upon line power restoration until updated ones are created. To indicate this type of failure, the control will flash the current Time Of Day Display to indicate that this display and the Volume Remaining Display may not be correct.

### Control Operation During Regeneration

During Regeneration a special regeneration display will take the place of either the Time Of Day or Volume Remaining Display. This display will contain the number one (to indicate only one regeneration signal is being sent) and the signal time remaining.

1. First the Regeneration Arrow turns on. Then the display below appears to indicate that a Regeneration Signal is being sent and how long it will be.

**For Example:**

(Regeneration Signal has started)  
(6.0 minute regeneration signal to be sent)  
(Regeneration Arrow On)

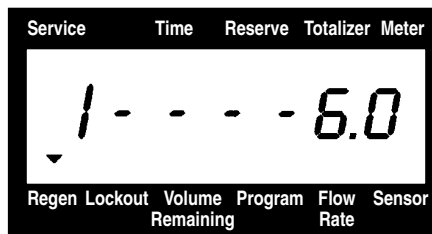

2. As time passes the countdown display will decrement in tenths of minutes until the time remaining reaches zero. When this occurs the control will return immediately to Service

**For Example:**

(Regeneration Signal has started)  
(3.2 minutes remain for signal)  
(Regeneration Arrow On)

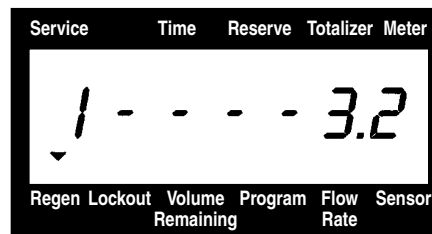

3. Pushing the Extra Cycle Button during a regeneration signal will immediately return the control to Service.
4. Pushing the Up or Down Set Button during a regeneration signal will adjust the signal time remaining. Actual Regeneration Signal programming will not be changed.

# 3200ET Remote Meter

## Control Operation (Cont'd.)

### Operation During Programming

The control will only enter the Program Mode with the timer in Service and operating on line power. While in the Program Mode the control will continue to operate normally monitoring water usage and keeping all displays up to date. Control programming is stored in memory permanently with or without line or battery backup power.

### Lockout Input Operation

The Lockout Arrow will turn on whenever a Lockout Signal is being received by the control. Any requests for regeneration will be delayed until this signal is removed. Regeneration will then proceed normally.

### Keypad Operation

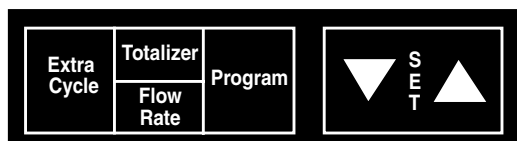

#### Extra Cycle Button -

Pushing this button will initiate a regeneration cycle independently of actual timer conditions.

1. With immediate regeneration timers this extra regeneration would occur immediately.
2. With delayed regeneration timers this extra regeneration would occur at the set Regeneration Time. A regeneration cycle can be forced to occur immediately by pushing and holding in for 5 seconds this button.

#### Totalizer/Flow Rate Button -

This button is used to view the Totalizer and Flow Rate Displays. Depressing the button once will display flow rate. Depressing the button again will display the total accumulation of water flow through the meter since it was last reset. Depressing the button once more will return the display to Time Of Day or Volume Remaining.

The Totalizer display is reset by depressing and holding this button for 25 seconds. During the 25 seconds, the Totalizer Arrow will flash as an indicator to the operator that the display is being reset properly.

#### Program Button -

This button is used by the installer to program those settings indicated on the front panel by red LEDs.

#### Up Set Button -

This button is used to set the current time of day, adjust time remaining in a regeneration cycle step, and in timer programming. The Up Arrow Button will increment a display setting.

#### Down Set Button -

This button is used to set the current time of day, adjust time remaining in a regeneration cycle step, and in timer programming. The Down Arrow Button will decrement a display setting.

### Low Battery Indicator



When the control is operating on line power this red LED will turn on whenever the **9V alkaline** battery (Not Included) used for memory backup needs to be replaced. The battery is stored against the timer backplate. In the event of a power outage, the battery will maintain current operating displays for approximately 24 hours at maximum battery capacity.



# 3200ET Remote Meter

## Timer Wiring Diagram

### Standard Remote Meter Wiring

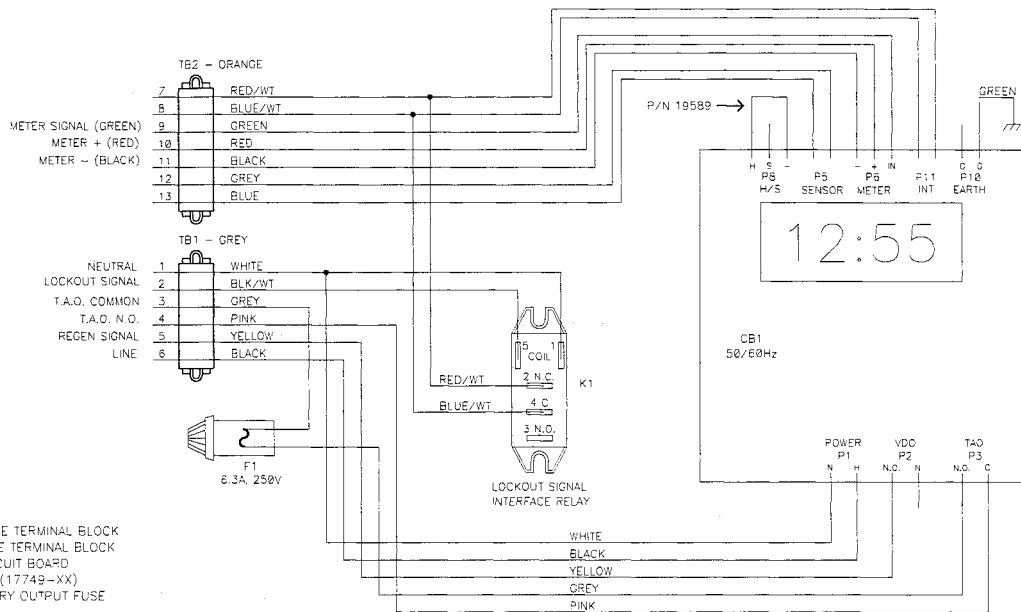

TB1 - HIGH VOLTAGE TERMINAL BLOCK  
 TB2 - LOW VOLTAGE TERMINAL BLOCK  
 CB1 - 3200ET CIRCUIT BOARD  
 K1 - SPDT RELAY (17749-XX)  
 F1 - TIMED AUXILIARY OUTPUT FUSE

**GENERAL WIRING NOTES:**

1. WIRE TERMINAL BLOCK POSITION #1 TO LEAD VALVE (VALVE #1) NEUTRAL.
2. WIRE TERMINAL BLOCK POSITION #2 TO INTERLOCKED POWER ON LEAD VALVE (VALVE #1).
3. WIRE TERMINAL BLOCK POSITION #5 TO LEAD VALVE (VALVE #1) START SIGNAL INPUT.
4. WIRE TERMINAL BLOCK POSITION #6 TO LEAD VALVE (VALVE #1) UNSWITCHED LINE.
5. JUMPER PLUG ON CIRCUIT BOARD PIN JW52 MUST BE REMOVED FOR REMOTE METER OPERATION.
4. PLEASE REFER TO EACH VALVES SERVICE MANUAL FOR SPECIFIC WIRING INFORMATION.

### 2900/3900 Multivalve System #7 Remote Meter Wiring

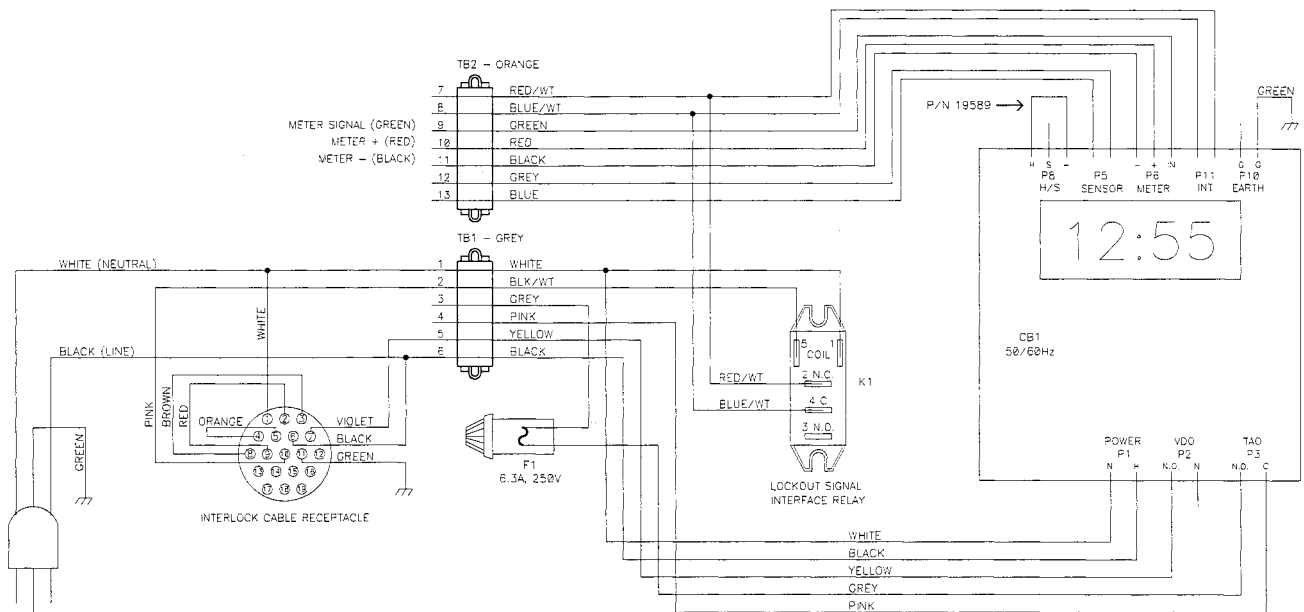

TB1 - HIGH VOLTAGE TERMINAL BLOCK  
 TB2 - LOW VOLTAGE TERMINAL BLOCK  
 CB1 - 3200ET CIRCUIT BOARD  
 K1 - SPDT RELAY (17749-XX)  
 F1 - TIMED AUXILIARY OUTPUT FUSE

**WIRING NOTE:**

1. CONNECT LEAD VALVE INTERLOCK CABLE TO REMOTE METER INTERLOCK CABLE RECEPTACLE.
2. JUMPER PLUG ON CIRCUIT BOARD PIN JW52 MUST BE REMOVED FOR REMOTE METER OPERATION.

# 3200ET Remote Meter

## 3200ET Timer Assemblies

(See opposite page for parts list)

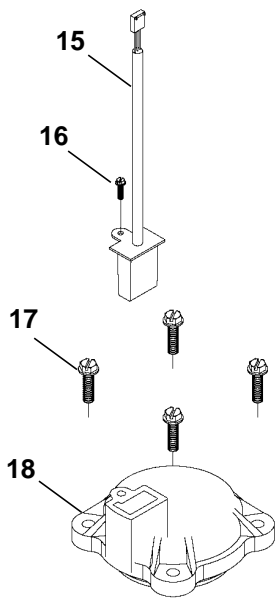

**Standard 3/4" To 2.0"  
Electronic Flow Meter  
Cap Assy.**

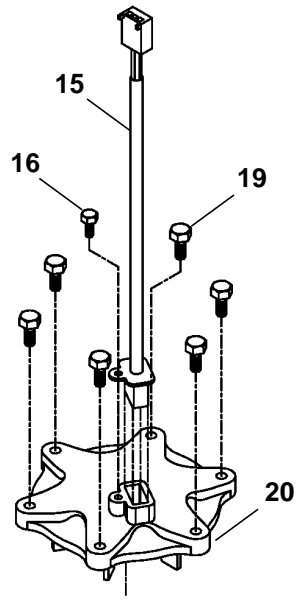

**Standard 3.0"  
Electronic Flow Meter  
Cap Assy.**

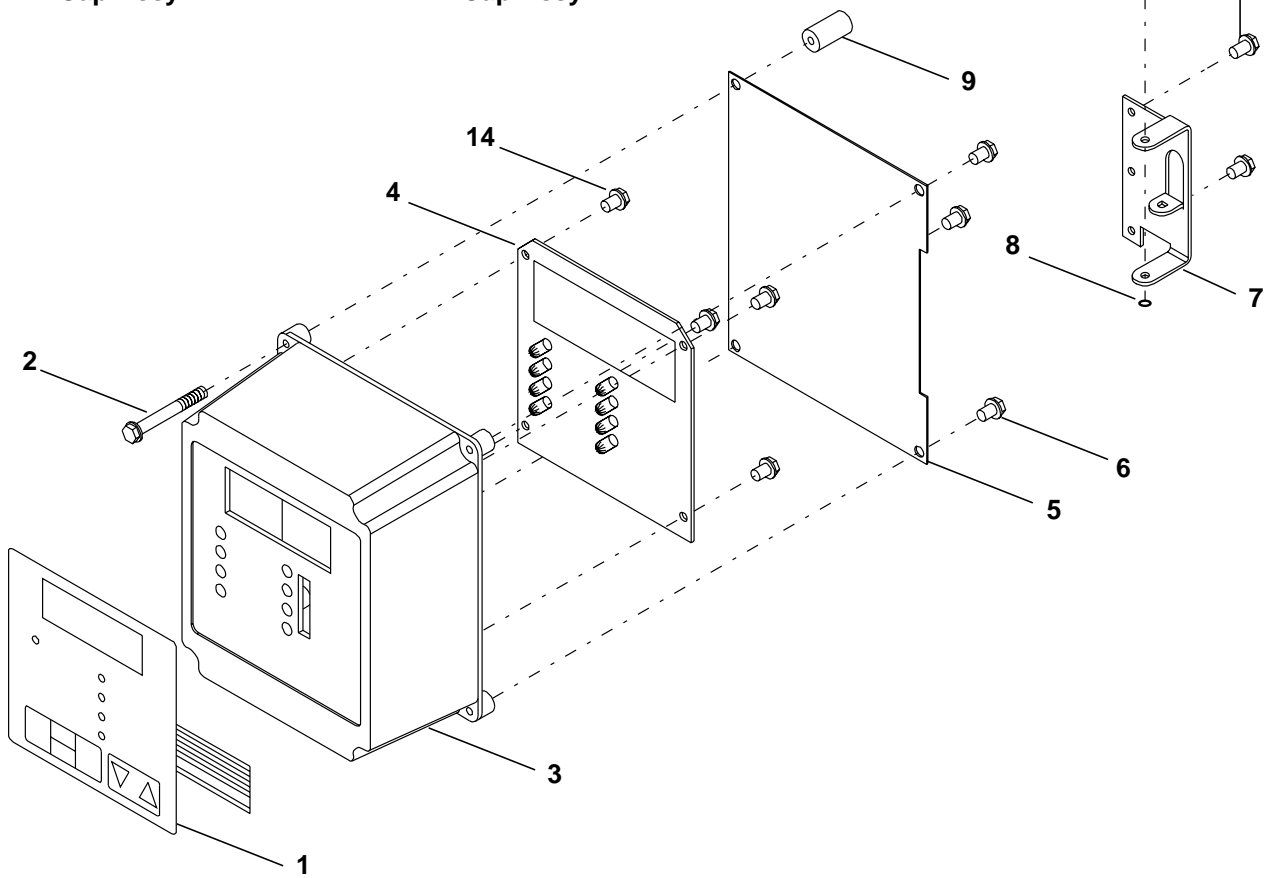
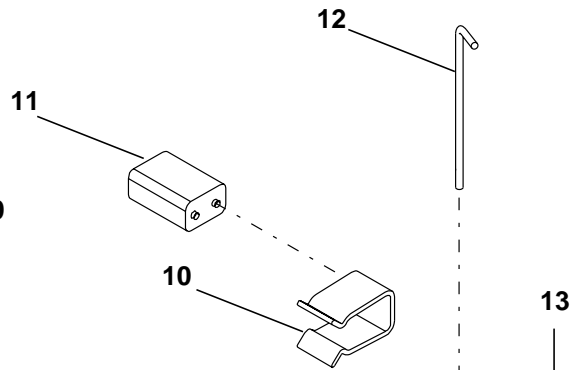

# 3200ET Remote Meter

## 3200 ET Timer Assemblies

### Parts List

Item No.	Quantity	Part No.	Description
1	1	19144-01	Assembly, Switch Pad (3200ET Remote)
2	1	18735	Screw, Hex Wash. #8 x 1 1/2
3	1	18741-01	Housing, Circuit Board - Right Hinge
4	1	27178-11	24V 3200ET Circuit Board (Version 2.0 Software)
	1	27178-13	120V 3200ET Circuit Board (Version 2.0 Software)
	1	27178-14	240V 3200ET Circuit Board (Version 2.0 Software)
5	1	18764	Shield, Circuit Board
6	3	12758	Screw, Hex Washer #10 x 5/8
7	1	18749	Bracket, Hinge
8	1	15159	O-Ring .005
9	1	18814	Spacer, Electronic Housing
10	1	17831-01	Battery Clip
11	1	-----	9V Alkaline Battery (Not Included)
12	1	14723	Pin, Timer Hinge
13	2	10300	Screw, Hex Washer #8 x 3/8
Not Shown	1	17749-00	Relay, SPDT (24V)
	1	17749-01	Relay, SPDT (120V)
	1	17749-02	Relay, SPDT (240V)
		40041-05	Harness Low Voltage Remote Meter w/3200ET
		40043-04	Harness, Power Remote Meter w/3200ET
		40044	Harness, 3200ET, Remote, Delay
Not Shown	1	19589	Plug, Jumper - Home And Step Switch
Not Shown	1	19891	Harness, Battery
14	4	17020	Screw, Slot Ind Hex, 6-20 x 3/8

### Optional Electronic Flow Meter Cap Parts List

Item No.	Quantity	Part No.	Description
15	1	19121-02	Assembly, Meter Cable
16	1	17798	Screw, Hex Washer
17	4	12473	Screw, Hex Washer #10-24 x 5/8
18	1	14716	Assembly, Meter Cap - Electronic (3/8" to 2.0" Meters)
19	6	12112	Screw, Hex Head
20	1	14716-01	Assembly, Meter Cap - 3.0" Electronic (3" Meter Only)

